

Arithmetic Progressions

Exercise 5.1

Question 1:

In which of the following situations, does the list of numbers involved make as arithmetic progression and why?

(i) The taxi fare after each km when the fare is Rs 15 for the first km and Rs 8 for each additional km.

(ii) The amount of air present in a cylinder when a vacuum pump removes $\frac{1}{4}$ of the air remaining in the cylinder at a time.

(iii) The cost of digging a well after every metre of digging, when it costs Rs 150 for the first metre and rises by Rs 50 for each subsequent metre.

(iv) The amount of money in the account every year, when Rs 10000 is deposited at compound interest at 8% per annum.

Answer:

(i) It can be observed that

Taxi fare for 1st km = 15

Taxi fare for first 2 km = 15 + 8 = 23

Taxi fare for first 3 km = 23 + 8 = 31

Taxi fare for first 4 km = 31 + 8 = 39

Clearly 15, 23, 31, 39 ... forms an A.P. because every term is 8 more than the preceding term.

(ii) Let the initial volume of air in a cylinder be V lit. In each stroke, the vacuum pump

removes $\frac{1}{4}$ of air remaining in the cylinder at a time. In other words, after every stroke,

only $1 - \frac{1}{4} = \frac{3}{4}$ th part of air will remain.

Therefore, volumes will be $V, \frac{3}{4}V, \left(\frac{3}{4}\right)^2V, \left(\frac{3}{4}\right)^3V, \dots$

Clearly, it can be observed that the adjacent terms of this series do not have the same difference between them. Therefore, this is not an A.P.

(iii) Cost of digging for first metre = 150

Cost of digging for first 2 metres = $150 + 50 = 200$

Cost of digging for first 3 metres = $200 + 50 = 250$

Cost of digging for first 4 metres = $250 + 50 = 300$

Clearly, 150, 200, 250, 300 ... forms an A.P. because every term is 50 more than the preceding term.

(iv) We know that if Rs P is deposited at $r\%$ compound interest per annum for n years,

our money will be $P\left(1 + \frac{r}{100}\right)^n$ after n years.

Therefore, after every year, our money will be

$$10000\left(1 + \frac{8}{100}\right), 10000\left(1 + \frac{8}{100}\right)^2, 10000\left(1 + \frac{8}{100}\right)^3, 10000\left(1 + \frac{8}{100}\right)^4, \dots$$

Clearly, adjacent terms of this series do not have the same difference between them. Therefore, this is not an A.P.

Question 2:

Write first four terms of the A.P. when the first term a and the common difference d are given as follows

(i) $a = 10, d = 10$

(ii) $a = -2, d = 0$

(iii) $a = 4, d = -3$

(iv) $a = -1, d = \frac{1}{2}$

(v) $a = -1.25, d = -0.25$

Answer:

(i) $a = 10, d = 10$

Let the series be $a_1, a_2, a_3, a_4, a_5 \dots$

$$a_1 = a = 10$$

$$a_2 = a_1 + d = 10 + 10 = 20$$

$$a_3 = a_2 + d = 20 + 10 = 30$$

$$a_4 = a_3 + d = 30 + 10 = 40$$

$$a_5 = a_4 + d = 40 + 10 = 50$$

Therefore, the series will be 10, 20, 30, 40, 50 ...

First four terms of this A.P. will be 10, 20, 30, and 40.

(ii) $a = -2, d = 0$

Let the series be $a_1, a_2, a_3, a_4 \dots$

$$a_1 = a = -2$$

$$a_2 = a_1 + d = -2 + 0 = -2$$

$$a_3 = a_2 + d = -2 + 0 = -2$$

$$a_4 = a_3 + d = -2 + 0 = -2$$

Therefore, the series will be -2, -2, -2, -2 ...

First four terms of this A.P. will be -2, -2, -2 and -2.

(iii) $a = 4, d = -3$

Let the series be $a_1, a_2, a_3, a_4 \dots$

$$a_1 = a = 4$$

$$a_2 = a_1 + d = 4 - 3 = 1$$

$$a_3 = a_2 + d = 1 - 3 = -2$$

$$a_4 = a_3 + d = -2 - 3 = -5$$

Therefore, the series will be 4, 1, -2 -5 ...

First four terms of this A.P. will be 4, 1, -2 and -5.

$$(iv) a = -1, d = \frac{1}{2}$$

Let the series be $a_1, a_2, a_3, a_4 \dots$

$$a_1 = a = -1$$

$$a_2 = a_1 + d = -1 + \frac{1}{2} = -\frac{1}{2}$$

$$a_3 = a_2 + d = -\frac{1}{2} + \frac{1}{2} = 0$$

$$a_4 = a_3 + d = 0 + \frac{1}{2} = \frac{1}{2}$$

Clearly, the series will be

$$-1, -\frac{1}{2}, 0, \frac{1}{2} \dots\dots\dots$$

First four terms of this A.P. will be $-1, -\frac{1}{2}, 0$ and $\frac{1}{2}$.

$$(v) a = -1.25, d = -0.25$$

Let the series be $a_1, a_2, a_3, a_4 \dots$

$$a_1 = a = -1.25$$

$$a_2 = a_1 + d = -1.25 - 0.25 = -1.50$$

$$a_3 = a_2 + d = -1.50 - 0.25 = -1.75$$

$$a_4 = a_3 + d = -1.75 - 0.25 = -2.00$$

Clearly, the series will be 1.25, -1.50, -1.75, -2.00

First four terms of this A.P. will be -1.25, -1.50, -1.75 and -2.00.

Question 3:

For the following A.P.s, write the first term and the common difference.

(i) 3, 1, -1, -3 ...

(ii) -5, -1, 3, 7 ...

(iii) $\frac{1}{3}, \frac{5}{3}, \frac{9}{3}, \frac{13}{3} \dots$

(iv) 0.6, 1.7, 2.8, 3.9 ...

Answer:

(i) 3, 1, -1, -3 ...

Here, first term, $a = 3$

Common difference, $d = \text{Second term} - \text{First term}$

$$= 1 - 3 = -2$$

(ii) -5, -1, 3, 7 ...

Here, first term, $a = -5$

Common difference, $d = \text{Second term} - \text{First term}$

$$= (-1) - (-5) = -1 + 5 = 4$$

$$(iii) \frac{1}{3}, \frac{5}{3}, \frac{9}{3}, \frac{13}{3}, \dots$$

Here, first term, $a = \frac{1}{3}$

Common difference, $d = \text{Second term} - \text{First term}$

$$= \frac{5}{3} - \frac{1}{3} = \frac{4}{3}$$

$$(iv) 0.6, 1.7, 2.8, 3.9 \dots$$

Here, first term, $a = 0.6$

Common difference, $d = \text{Second term} - \text{First term}$

$$= 1.7 - 0.6$$

$$= 1.1$$

Question 4:

Which of the following are APs? If they form an A.P. find the common difference d and write three more terms.

(i) 2, 4, 8, 16 ...

(ii) $2, \frac{5}{2}, 3, \frac{7}{2}, \dots$

(iii) - 1.2, - 3.2, - 5.2, - 7.2 ...

(iv) - 10, - 6, - 2, 2 ...

(v) $3, 3 + \sqrt{2}, 3 + 2\sqrt{2}, 3 + 3\sqrt{2}, \dots$

(vi) 0.2, 0.22, 0.222, 0.2222

(vii) 0, - 4, - 8, - 12 ...

(viii) $-\frac{1}{2}, -\frac{1}{2}, -\frac{1}{2}, -\frac{1}{2}, \dots$

(ix) 1, 3, 9, 27 ...

(x) $a, 2a, 3a, 4a, \dots$

(xi) $a, a^2, a^3, a^4 \dots$ (xii) $\sqrt{2}, \sqrt{8}, \sqrt{18}, \sqrt{32} \dots$

(xiii) $\sqrt{3}, \sqrt{6}, \sqrt{9}, \sqrt{12} \dots$

(xiv) $1^2, 3^2, 5^2, 7^2 \dots$

(xv) $1^2, 5^2, 7^2, 73 \dots$

Answer:

(i) 2, 4, 8, 16 ...

It can be observed that

$$a_2 - a_1 = 4 - 2 = 2$$

$$a_3 - a_2 = 8 - 4 = 4$$

$$a_4 - a_3 = 16 - 8 = 8$$

i.e., $a_{k+1} - a_k$ is not the same every time. Therefore, the given numbers are not forming an A.P.

(ii) $2, \frac{5}{2}, 3, \frac{7}{2} \dots$

It can be observed that

$$a_2 - a_1 = \frac{5}{2} - 2 = \frac{1}{2}$$

$$a_3 - a_2 = 3 - \frac{5}{2} = \frac{1}{2}$$

$$a_4 - a_3 = \frac{7}{2} - 3 = \frac{1}{2}$$

i.e., $a_{k+1} - a_k$ is same every time.

Therefore, $d = \frac{1}{2}$ and the given numbers are in A.P.

Three more terms are

$$a_5 = \frac{7}{2} + \frac{1}{2} = 4$$

$$a_6 = 4 + \frac{1}{2} = \frac{9}{2}$$

$$a_7 = \frac{9}{2} + \frac{1}{2} = 5$$

(iii) -1.2, -3.2, -5.2, -7.2 ...

It can be observed that

$$a_2 - a_1 = (-3.2) - (-1.2) = -2$$

$$a_3 - a_2 = (-5.2) - (-3.2) = -2$$

$$a_4 - a_3 = (-7.2) - (-5.2) = -2$$

i.e., $a_{k+1} - a_k$ is same every time. Therefore, $d = -2$

The given numbers are in A.P.

Three more terms are

$$a_5 = -7.2 - 2 = -9.2$$

$$a_6 = -9.2 - 2 = -11.2$$

$$a_7 = -11.2 - 2 = -13.2$$

(iv) -10, -6, -2, 2 ...

It can be observed that

$$a_2 - a_1 = (-6) - (-10) = 4$$

$$a_3 - a_2 = (-2) - (-6) = 4$$

$$a_4 - a_3 = (2) - (-2) = 4$$

i.e., $a_{k+1} - a_k$ is same every time. Therefore, $d = 4$

The given numbers are in A.P.

Three more terms are

$$a_5 = 2 + 4 = 6$$

$$a_6 = 6 + 4 = 10$$

$$a_7 = 10 + 4 = 14$$

$$(v) \quad 3, 3 + \sqrt{2}, 3 + 2\sqrt{2}, 3 + 3\sqrt{2}, \dots$$

It can be observed that

$$a_2 - a_1 = 3 + \sqrt{2} - 3 = \sqrt{2}$$

$$a_3 - a_2 = 3 + 2\sqrt{2} - 3 - \sqrt{2} = \sqrt{2}$$

$$a_4 - a_3 = 3 + 3\sqrt{2} - 3 - 2\sqrt{2} = \sqrt{2}$$

i.e., $a_{k+1} - a_k$ is same every time. Therefore, $d = \sqrt{2}$

The given numbers are in A.P.

Three more terms are

$$a_5 = 3 + 3\sqrt{2} + \sqrt{2} = 3 + 4\sqrt{2}$$

$$a_6 = 3 + 4\sqrt{2} + \sqrt{2} = 3 + 5\sqrt{2}$$

$$a_7 = 3 + 5\sqrt{2} + \sqrt{2} = 3 + 6\sqrt{2}$$

$$(vi) \quad 0.2, 0.22, 0.222, 0.2222 \dots$$

It can be observed that

$$a_2 - a_1 = 0.22 - 0.2 = 0.02$$

$$a_3 - a_2 = 0.222 - 0.22 = 0.002$$

$$a_4 - a_3 = 0.2222 - 0.222 = 0.0002$$

i.e., $a_{k+1} - a_k$ is not the same every time.

Therefore, the given numbers are not in A.P.

(vii) 0, -4, -8, -12 ...

It can be observed that

$$a_2 - a_1 = (-4) - 0 = -4$$

$$a_3 - a_2 = (-8) - (-4) = -4$$

$$a_4 - a_3 = (-12) - (-8) = -4$$

i.e., $a_{k+1} - a_k$ is same every time. Therefore, $d = -4$

The given numbers are in A.P.

Three more terms are

$$a_5 = -12 - 4 = -16$$

$$a_6 = -16 - 4 = -20$$

$$a_7 = -20 - 4 = -24$$

(viii) $-\frac{1}{2}, -\frac{1}{2}, -\frac{1}{2}, -\frac{1}{2} \dots$

It can be observed that

$$a_2 - a_1 = \left(-\frac{1}{2}\right) - \left(-\frac{1}{2}\right) = 0$$

$$a_3 - a_2 = \left(-\frac{1}{2}\right) - \left(-\frac{1}{2}\right) = 0$$

$$a_4 - a_3 = \left(-\frac{1}{2}\right) - \left(-\frac{1}{2}\right) = 0$$

i.e., $a_{k+1} - a_k$ is same every time. Therefore, $d = 0$

The given numbers are in A.P.

Three more terms are

$$a_5 = -\frac{1}{2} - 0 = -\frac{1}{2}$$

$$a_6 = -\frac{1}{2} - 0 = -\frac{1}{2}$$

$$a_7 = -\frac{1}{2} - 0 = -\frac{1}{2}$$

(ix) 1, 3, 9, 27 ...

It can be observed that

$$a_2 - a_1 = 3 - 1 = 2$$

$$a_3 - a_2 = 9 - 3 = 6$$

$$a_4 - a_3 = 27 - 9 = 18$$

i.e., $a_{k+1} - a_k$ is not the same every time.

Therefore, the given numbers are not in A.P.

(x) a, 2a, 3a, 4a ...

It can be observed that

$$a_2 - a_1 = 2a - a = a$$

$$a_3 - a_2 = 3a - 2a = a$$

$$a_4 - a_3 = 4a - 3a = a$$

i.e., $a_{k+1} - a_k$ is same every time. Therefore, $d = a$

The given numbers are in A.P.

Three more terms are

$$a_5 = 4a + a = 5a$$

$$a_6 = 5a + a = 6a$$

$$a_7 = 6a + a = 7a$$

(xi) $a, a^2, a^3, a^4 \dots$

It can be observed that

$$a_2 - a_1 = a^2 - a = a(a - 1)$$

$$a_3 - a_2 = a^3 - a^2 = a^2(a - 1)$$

$$a_4 - a_3 = a^4 - a^3 = a^3(a - 1)$$

i.e., $a_{k+1} - a_k$ is not the same every time.

Therefore, the given numbers are not in A.P.

(xii) $\sqrt{2}, \sqrt{8}, \sqrt{18}, \sqrt{32} \dots$

It can be observed that

$$a_2 - a_1 = \sqrt{8} - \sqrt{2} = 2\sqrt{2} - \sqrt{2} = \sqrt{2}$$

$$a_3 - a_2 = \sqrt{18} - \sqrt{8} = 3\sqrt{2} - 2\sqrt{2} = \sqrt{2}$$

$$a_4 - a_3 = \sqrt{32} - \sqrt{18} = 4\sqrt{2} - 3\sqrt{2} = \sqrt{2}$$

i.e., $a_{k+1} - a_k$ is same every time.

Therefore, the given numbers are in A.P.

And, $d = \sqrt{2}$

Three more terms are

$$a_5 = \sqrt{32} + \sqrt{2} = 4\sqrt{2} + \sqrt{2} = 5\sqrt{2} = \sqrt{50}$$

$$a_6 = 5\sqrt{2} + \sqrt{2} = 6\sqrt{2} = \sqrt{72}$$

$$a_7 = 6\sqrt{2} + \sqrt{2} = 7\sqrt{2} = \sqrt{98}$$

(xiii) $\sqrt{3}, \sqrt{6}, \sqrt{9}, \sqrt{12} \dots$

It can be observed that

$$a_2 - a_1 = \sqrt{6} - \sqrt{3} = \sqrt{3 \times 2} - \sqrt{3} = \sqrt{3}(\sqrt{2} - 1)$$

$$a_3 - a_2 = \sqrt{9} - \sqrt{6} = 3 - \sqrt{6} = \sqrt{3}(\sqrt{3} - \sqrt{2})$$

$$a_4 - a_3 = \sqrt{12} - \sqrt{9} = 2\sqrt{3} - \sqrt{3 \times 3} = \sqrt{3}(2 - \sqrt{3})$$

i.e., $a_{k+1} - a_k$ is not the same every time.

Therefore, the given numbers are not in A.P.

(xiv) $1^2, 3^2, 5^2, 7^2 \dots$

Or, 1, 9, 25, 49

It can be observed that

$$a_2 - a_1 = 9 - 1 = 8$$

$$a_3 - a_2 = 25 - 9 = 16$$

$$a_4 - a_3 = 49 - 25 = 24$$

i.e., $a_{k+1} - a_k$ is not the same every time.

Therefore, the given numbers are not in A.P.

$$(xv) 1^2, 5^2, 7^2, 73 \dots$$

$$\text{Or } 1, 25, 49, 73 \dots$$

It can be observed that

$$a_2 - a_1 = 25 - 1 = 24$$

$$a_3 - a_2 = 49 - 25 = 24$$

$$a_4 - a_3 = 73 - 49 = 24$$

i.e., $a_{k+1} - a_k$ is same every time.

Therefore, the given numbers are in A.P.

$$\text{And, } d = 24$$

Three more terms are

$$a_5 = 73 + 24 = 97$$

$$a_6 = 97 + 24 = 121$$

$$a_7 = 121 + 24 = 145$$

Exercise 5.2

Question 1:

Fill in the blanks in the following table, given that a is the first term, d the common difference and a_n the n^{th} term of the A.P.

	a	d	n	a_n
I	7	3	8
II	- 18	10	0
III	- 3	18	- 5
IV	- 18.9	2.5	3.6
V	3.5	0	105

Answer:

I. $a = 7, d = 3, n = 8, a_n = ?$

We know that,

For an A.P. $a_n = a + (n - 1) d$

$$= 7 + (8 - 1) 3$$

$$= 7 + (7) 3$$

$$= 7 + 21 = 28$$

Hence, $a_n = 28$

II. Given that

$a = -18, n = 10, a_n = 0, d = ?$

We know that,

$$a_n = a + (n - 1) d$$

$$0 = -18 + (10 - 1) d$$

$$18 = 9d$$

$$d = \frac{18}{9} = 2$$

Hence, common difference, $d = 2$

III. Given that

$$d = -3, n = 18, a_n = -5$$

We know that,

$$a_n = a + (n - 1) d$$

$$-5 = a + (18 - 1) (-3)$$

$$-5 = a + (17) (-3)$$

$$-5 = a - 51$$

$$a = 51 - 5 = 46$$

Hence, $a = 46$

$$\text{IV. } a = -18.9, d = 2.5, a_n = 3.6, n = ?$$

We know that,

$$a_n = a + (n - 1) d$$

$$3.6 = -18.9 + (n - 1) 2.5$$

$$3.6 + 18.9 = (n - 1) 2.5$$

$$22.5 = (n - 1) 2.5$$

$$(n-1) = \frac{22.5}{2.5}$$

$$n-1 = 9$$

$$n = 10$$

Hence, $n = 10$

V. $a = 3.5$, $d = 0$, $n = 105$, $a_n = ?$

We know that,

$$a_n = a + (n - 1) d$$

$$a_n = 3.5 + (105 - 1) 0$$

$$a_n = 3.5 + 104 \times 0$$

$$a_n = 3.5$$

Hence, $a_n = 3.5$

Question 2:

Choose the correct choice in the following and justify

I. 30th term of the A.P: 10, 7, 4, ..., is

A. 97 B. 77 C. - 77 D. - 87

II 11th term of the A.P. $-3, -\frac{1}{2}, 2, \dots$ is

A. 28 B. 22 C. - 38 D. $-48\frac{1}{2}$

Answer:

I. Given that

A.P. 10, 7, 4, ...

First term, $a = 10$

Common difference, $d = a_2 - a_1 = 7 - 10$

$$= -3$$

We know that, $a_n = a + (n - 1) d$

$$a_{30} = 10 + (30 - 1) (-3)$$

$$a_{30} = 10 + (29) (-3)$$

$$a_{30} = 10 - 87 = -77$$

Hence, the correct answer is C.

II. Given that, A.P. $-3, -\frac{1}{2}, 2, \dots$

First term $a = -3$

Common difference, $d = a_2 - a_1$

$$= -\frac{1}{2} - (-3)$$

$$= -\frac{1}{2} + 3 = \frac{5}{2}$$

We know that,

$$a_n = a + (n-1)d$$

$$a_{11} = -3 + (11-1)\left(\frac{5}{2}\right)$$

$$a_{11} = -3 + (10)\left(\frac{5}{2}\right)$$

$$a_{11} = -3 + 25$$

$$a_{11} = 22$$

Hence, the answer is B.

Question 3:

In the following APs find the missing term in the boxes

I. 2, , 26

II. , 13, , 3

III. 5, , , $9\frac{1}{2}$

IV. -4, , , , , 6

V. , 38, , , , -22

Answer:

I. 2, , 26

For this A.P.,

$$a = 2$$

$$a_3 = 26$$

We know that, $a_n = a + (n - 1) d$

$$a_3 = 2 + (3 - 1) d$$

$$26 = 2 + 2d$$

$$24 = 2d$$

$$d = 12$$

$$a_2 = 2 + (2 - 1) 12$$

$$= 14$$

Therefore, 14 is the missing term.

$$\text{II. } \square, 13, \square, 3$$

For this A.P.,

$$a_2 = 13 \text{ and}$$

$$a_4 = 3$$

We know that, $a_n = a + (n - 1) d$

$$a_2 = a + (2 - 1) d$$

$$13 = a + d \text{ (I)}$$

$$a_4 = a + (4 - 1) d$$

$$3 = a + 3d \text{ (II)}$$

On subtracting (I) from (II), we obtain

$$-10 = 2d$$

$$d = -5$$

From equation (I), we obtain

$$13 = a + (-5)$$

$$a = 18$$

$$a_3 = 18 + (3 - 1)(-5)$$

$$= 18 + 2(-5) = 18 - 10 = 8$$

Therefore, the missing terms are 18 and 8 respectively.

$$\text{III. } 5, \square, \square, 9\frac{1}{2}$$

For this A.P.,

$$a = 5$$

$$a_4 = 9\frac{1}{2} = \frac{19}{2}$$

We know that,

$$a_n = a + (n-1)d$$

$$a_4 = a + (4-1)d$$

$$\frac{19}{2} = 5 + 3d$$

$$\frac{19}{2} - 5 = 3d$$

$$\frac{9}{2} = 3d$$

$$d = \frac{3}{2}$$

$$a_2 = a + d = 5 + \frac{3}{2} = \frac{13}{2}$$

$$a_3 = a + 2d = 5 + 2\left(\frac{3}{2}\right) = 8$$

Therefore, the missing terms are $\frac{13}{2}$ and 8 respectively.

$$\text{IV. } -4, \square, \square, \square, \square, 6$$

For this A.P.,

$$a = -4 \text{ and}$$

$$a_6 = 6$$

We know that,

$$a_n = a + (n - 1) d$$

$$a_6 = a + (6 - 1) d$$

$$6 = -4 + 5d$$

$$10 = 5d$$

$$d = 2$$

$$a_2 = a + d = -4 + 2 = -2$$

$$a_3 = a + 2d = -4 + 2(2) = 0$$

$$a_4 = a + 3d = -4 + 3(2) = 2$$

$$a_5 = a + 4d = -4 + 4(2) = 4$$

Therefore, the missing terms are -2, 0, 2, and 4 respectively.

$$\text{V. } \square, 38, \square, \square, \square, -22$$

For this A.P.,

$$a_2 = 38$$

$$a_6 = -22$$

We know that

$$a_n = a + (n - 1) d$$

$$a_2 = a + (2 - 1) d$$

$$38 = a + d \quad (1)$$

$$a_6 = a + (6 - 1) d$$

$$-22 = a + 5d \quad (2)$$

On subtracting equation (1) from (2), we obtain

$$-22 - 38 = 4d$$

$$-60 = 4d$$

$$d = -15$$

$$a = a_2 - d = 38 - (-15) = 53$$

$$a_3 = a + 2d = 53 + 2(-15) = 23$$

$$a_4 = a + 3d = 53 + 3(-15) = 8$$

$$a_5 = a + 4d = 53 + 4(-15) = -7$$

Therefore, the missing terms are 53, 23, 8, and -7 respectively.

Question 4:

Which term of the A.P. 3, 8, 13, 18, ... is 78?

Answer:

3, 8, 13, 18, ...

For this A.P.,

$$a = 3$$

$$d = a_2 - a_1 = 8 - 3 = 5$$

Let n^{th} term of this A.P. be 78.

$$a_n = a + (n - 1) d$$

$$78 = 3 + (n - 1) 5$$

$$75 = (n - 1) 5$$

$$(n - 1) = 15$$

$$n = 16$$

Hence, 16^{th} term of this A.P. is 78.

Question 5:

Find the number of terms in each of the following A.P.

I. 7, 13, 19, ..., 205

II. $18, 15\frac{1}{2}, 13, \dots, -47$

Answer:

I. 7, 13, 19, ..., 205

For this A.P.,

$$a = 7$$

$$d = a_2 - a_1 = 13 - 7 = 6$$

Let there are n terms in this A.P.

$$a_n = 205$$

We know that

$$a_n = a + (n - 1) d$$

$$\text{Therefore, } 205 = 7 + (n - 1) 6$$

$$198 = (n - 1) 6$$

$$33 = (n - 1)$$

$$n = 34$$

Therefore, this given series has 34 terms in it.

$$\text{II. } 18, 15\frac{1}{2}, 13, \dots, -47$$

For this A.P.,

$$a = 18$$

$$d = a_2 - a_1 = 15\frac{1}{2} - 18$$

$$d = \frac{31 - 36}{2} = -\frac{5}{2}$$

Let there are n terms in this A.P.

Therefore, $a_n = -47$ and we know that,

$$a_n = a + (n-1)d$$

$$-47 = 18 + (n-1)\left(-\frac{5}{2}\right)$$

$$-47 - 18 = (n-1)\left(-\frac{5}{2}\right)$$

$$-65 = (n-1)\left(-\frac{5}{2}\right)$$

$$(n-1) = \frac{-130}{-5}$$

$$(n-1) = 26$$

$$n = 27$$

Therefore, this given A.P. has 27 terms in it.

Question 6:

Check whether - 150 is a term of the A.P. 11, 8, 5, 2, ...

Answer:

For this A.P.,

$$a = 11$$

$$d = a_2 - a_1 = 8 - 11 = -3$$

Let -150 be the n^{th} term of this A.P.

We know that,

$$a_n = a + (n-1)d$$

$$-150 = 11 + (n-1)(-3)$$

$$-150 = 11 - 3n + 3$$

$$-164 = -3n$$

$$n = \frac{164}{3}$$

Clearly, n is not an integer.

Therefore, -150 is not a term of this A.P.

Question 7:

Find the 31st term of an A.P. whose 11th term is 38 and the 16th term is 73

Answer:

Given that,

$$a_{11} = 38$$

$$a_{16} = 73$$

We know that,

$$a_n = a + (n - 1) d$$

$$a_{11} = a + (11 - 1) d$$

$$38 = a + 10d \quad (1)$$

Similarly,

$$a_{16} = a + (16 - 1) d$$

$$73 = a + 15d \quad (2)$$

On subtracting (1) from (2), we obtain

$$35 = 5d$$

$$d = 7$$

From equation (1),

$$38 = a + 10 \times (7)$$

$$38 - 70 = a$$

$$a = -32$$

$$a_{31} = a + (31 - 1) d$$

$$= -32 + 30(7)$$

$$= -32 + 210$$

$$= 178$$

Hence, 31st term is 178.

Question 8:

An A.P. consists of 50 terms of which 3rd term is 12 and the last term is 106. Find the 29th term

Answer:

Given that,

$$a_3 = 12$$

$$a_{50} = 106$$

We know that,

$$a_n = a + (n - 1) d$$

$$a_3 = a + (3 - 1) d$$

$$12 = a + 2d \text{ (I)}$$

$$\text{Similarly, } a_{50} = a + (50 - 1) d$$

$$106 = a + 49d \text{ (II)}$$

On subtracting (I) from (II), we obtain

$$94 = 47d$$

$$d = 2$$

From equation (I), we obtain

$$12 = a + 2(2)$$

$$a = 12 - 4 = 8$$

$$a_{29} = a + (29 - 1)d$$

$$a_{29} = 8 + (28)2$$

$$a_{29} = 8 + 56 = 64$$

Therefore, 29th term is 64.

Question 9:

If the 3rd and the 9th terms of an A.P. are 4 and - 8 respectively. Which term of this A.P. is zero.

Answer:

Given that,

$$a_3 = 4$$

$$a_9 = -8$$

We know that,

$$a_n = a + (n - 1)d$$

$$a_3 = a + (3 - 1)d$$

$$4 = a + 2d \text{ (I)}$$

$$a_9 = a + (9 - 1)d$$

$$-8 = a + 8d \text{ (II)}$$

On subtracting equation (I) from (II), we obtain

$$-12 = 6d$$

$$d = -2$$

From equation (I), we obtain

$$4 = a + 2(-2)$$

$$4 = a - 4$$

$$a = 8$$

Let n^{th} term of this A.P. be zero.

$$a_n = a + (n - 1)d$$

$$0 = 8 + (n - 1)(-2)$$

$$0 = 8 - 2n + 2$$

$$2n = 10$$

$$n = 5$$

Hence, 5^{th} term of this A.P. is 0.

Question 10:

If 17^{th} term of an A.P. exceeds its 10^{th} term by 7. Find the common difference.

Answer:

We know that,

For an A.P., $a_n = a + (n - 1)d$

$$a_{17} = a + (17 - 1) d$$

$$a_{17} = a + 16d$$

Similarly, $a_{10} = a + 9d$

It is given that

$$a_{17} - a_{10} = 7$$

$$(a + 16d) - (a + 9d) = 7$$

$$7d = 7$$

$$d = 1$$

Therefore, the common difference is 1.

Question 11:

Which term of the A.P. 3, 15, 27, 39, ... will be 132 more than its 54th term?

Answer:

Given A.P. is 3, 15, 27, 39, ...

$$a = 3$$

$$d = a_2 - a_1 = 15 - 3 = 12$$

$$a_{54} = a + (54 - 1) d$$

$$= 3 + (53) (12)$$

$$= 3 + 636 = 639$$

$$132 + 639 = 771$$

We have to find the term of this A.P. which is 771.

Let n^{th} term be 771.

$$a_n = a + (n - 1) d$$

$$771 = 3 + (n - 1) 12$$

$$768 = (n - 1) 12$$

$$(n - 1) = 64$$

$$n = 65$$

Therefore, 65^{th} term was 132 more than 54^{th} term.

Alternatively,

Let n^{th} term be 132 more than 54^{th} term.

$$\begin{aligned} n &= 54 + \frac{132}{12} \\ &= 54 + 11 = 65^{\text{th}} \text{ term} \end{aligned}$$

Question 12:

Two APs have the same common difference. The difference between their 100^{th} term is 100, what is the difference between their 1000^{th} terms?

Answer:

Let the first term of these A.P.s be a_1 and a_2 respectively and the common difference of these A.P.s be d .

For first A.P.,

$$a_{100} = a_1 + (100 - 1) d$$

$$= a_1 + 99d$$

$$a_{1000} = a_1 + (1000 - 1) d$$

$$a_{1000} = a_1 + 999d$$

For second A.P.,

$$a_{100} = a_2 + (100 - 1) d$$

$$= a_2 + 99d$$

$$a_{1000} = a_2 + (1000 - 1) d$$

$$= a_2 + 999d$$

Given that, difference between

100th term of these A.P.s = 100

$$\text{Therefore, } (a_1 + 99d) - (a_2 + 99d) = 100$$

$$a_1 - a_2 = 100 \quad (1)$$

Difference between 1000th terms of these A.P.s

$$(a_1 + 999d) - (a_2 + 999d) = a_1 - a_2$$

From equation (1),

This difference, $a_1 - a_2 = 100$

Hence, the difference between 1000th terms of these A.P. will be 100.

Question 13:

How many three digit numbers are divisible by 7

Answer:

First three-digit number that is divisible by 7 = 105

Next number = $105 + 7 = 112$

Therefore, 105, 112, 119, ...

All are three digit numbers which are divisible by 7 and thus, all these are terms of an A.P. having first term as 105 and common difference as 7.

The maximum possible three-digit number is 999. When we divide it by 7, the remainder will be 5. Clearly, $999 - 5 = 994$ is the maximum possible three-digit number that is divisible by 7.

The series is as follows.

105, 112, 119, ..., 994

Let 994 be the n th term of this A.P.

$$a = 105$$

$$d = 7$$

$$a_n = 994$$

$$n = ?$$

$$a_n = a + (n - 1) d$$

$$994 = 105 + (n - 1) 7$$

$$889 = (n - 1) 7$$

$$(n - 1) = 127$$

$$n = 128$$

Therefore, 128 three-digit numbers are divisible by 7.

Question 14:

How many multiples of 4 lie between 10 and 250?

Answer:

First multiple of 4 that is greater than 10 is 12. Next will be 16.

Therefore, 12, 16, 20, 24, ...

All these are divisible by 4 and thus, all these are terms of an A.P. with first term as 12 and common difference as 4.

When we divide 250 by 4, the remainder will be 2. Therefore, $250 - 2 = 248$ is divisible by 4.

The series is as follows.

12, 16, 20, 24, ..., 248

Let 248 be the n^{th} term of this A.P.

$$a = 12$$

$$d = 4$$

$$a_n = 248$$

$$a_n = a + (n-1)d$$

$$248 = 12 + (n-1)4$$

$$\frac{236}{4} = n-1$$

$$59 = n-1$$

$$n = 60$$

Therefore, there are 60 multiples of 4 between 10 and 250.

Question 15:

For what value of n , are the n^{th} terms of two APs 63, 65, 67, ... and 3, 10, 17, ... equal

Answer:

63, 65, 67, ...

$$a = 63$$

$$d = a_2 - a_1 = 65 - 63 = 2$$

n^{th} term of this A.P. = $a_n = a + (n - 1) d$

$$a_n = 63 + (n - 1) 2 = 63 + 2n - 2$$

$$a_n = 61 + 2n \quad (1)$$

3, 10, 17, ...

$$a = 3$$

$$d = a_2 - a_1 = 10 - 3 = 7$$

n^{th} term of this A.P. = $3 + (n - 1) 7$

$$a_n = 3 + 7n - 7$$

$$a_n = 7n - 4 \quad (2)$$

It is given that, n^{th} term of these A.P.s are equal to each other.

Equating both these equations, we obtain

$$61 + 2n = 7n - 4$$

$$61 + 4 = 5n$$

$$5n = 65$$

$$n = 13$$

Therefore, 13^{th} terms of both these A.P.s are equal to each other.

Question 16:

Determine the A.P. whose third term is 16 and the 7^{th} term exceeds the 5^{th} term by 12.

Answer:

$$=a_3 = 16$$

$$a + (3 - 1) d = 16$$

$$a + 2d = 16 \quad (1)$$

$$a_7 - a_5 = 12$$

$$[a + (7 - 1) d] - [a + (5 - 1) d] = 12$$

$$(a + 6d) - (a + 4d) = 12$$

$$2d = 12$$

$$d = 6$$

From equation (1), we obtain

$$a + 2(6) = 16$$

$$a + 12 = 16$$

$$a = 4$$

Therefore, A.P. will be

4, 10, 16, 22, ...

Question 17:

Find the 20th term from the last term of the A.P. 3, 8, 13, ..., 253

Answer:

Given A.P. is

3, 8, 13, ..., 253

Common difference for this A.P. is 5.

Therefore, this A.P. can be written in reverse order as

253, 248, 243, ..., 13, 8, 3

For this A.P.,

$$a = 253$$

$$d = 248 - 253 = -5$$

$$n = 20$$

$$a_{20} = a + (20 - 1) d$$

$$a_{20} = 253 + (19) (-5)$$

$$a_{20} = 253 - 95$$

$$a = 158$$

Therefore, 20th term from the last term is 158.

Question 18:

The sum of 4th and 8th terms of an A.P. is 24 and the sum of the 6th and 10th terms is 44. Find the first three terms of the A.P.

Answer:

We know that,

$$a_n = a + (n - 1) d$$

$$a_4 = a + (4 - 1) d$$

$$a_4 = a + 3d$$

Similarly,

$$a_8 = a + 7d$$

$$a_6 = a + 5d$$

$$a_{10} = a + 9d$$

Given that, $a_4 + a_8 = 24$

$$a + 3d + a + 7d = 24$$

$$2a + 10d = 24$$

$$a + 5d = 12 \quad (1)$$

$$a_6 + a_{10} = 44$$

$$a + 5d + a + 9d = 44$$

$$2a + 14d = 44$$

$$a + 7d = 22 \quad (2)$$

On subtracting equation (1) from (2), we obtain

$$2d = 22 - 12$$

$$2d = 10$$

$$d = 5$$

From equation (1), we obtain

$$a + 5d = 12$$

$$a + 5(5) = 12$$

$$a + 25 = 12$$

$$a = -13$$

$$a_2 = a + d = -13 + 5 = -8$$

$$a_3 = a_2 + d = -8 + 5 = -3$$

Therefore, the first three terms of this A.P. are -13, -8, and -3.

Question 19:

Subba Rao started work in 1995 at an annual salary of Rs 5000 and received an increment of Rs 200 each year. In which year did his income reach Rs 7000?

Answer:

It can be observed that the incomes that Subba Rao obtained in various years are in A.P. as every year, his salary is increased by Rs 200.

Therefore, the salaries of each year after 1995 are

5000, 5200, 5400, ...

Here, $a = 5000$

$d = 200$

Let after n^{th} year, his salary be Rs 7000.

Therefore, $a_n = a + (n - 1) d$

$$7000 = 5000 + (n - 1) 200$$

$$200(n - 1) = 2000$$

$$(n - 1) = 10$$

$$n = 11$$

Therefore, in 11th year, his salary will be Rs 7000.

Question 20:

Ramkali saved Rs 5 in the first week of a year and then increased her weekly saving by Rs 1.75. If in the n^{th} week, her weekly savings become Rs 20.75, find n.

Answer:

Given that,

$$a = 5$$

$$d = 1.75$$

$$a_n = 20.75$$

$$n = ?$$

$$a_n = a + (n - 1) d$$

$$20.75 = 5 + (n - 1)1.75$$

$$15.75 = (n - 1)1.75$$

$$(n - 1) = \frac{15.75}{1.75} = \frac{1575}{175}$$

$$= \frac{63}{7} = 9$$

$$n - 1 = 9$$

$$n = 10$$

Hence, n is 10.

Exercise 5.3

Question 1:

Find the sum of the following APs.

(i) 2, 7, 12 ,..., to 10 terms.

(ii) - 37, - 33, - 29 ,..., to 12 terms

(iii) 0.6, 1.7, 2.8 ,....., to 100 terms

(iv) $\frac{1}{15}, \frac{1}{12}, \frac{1}{10}$,....., to 11 terms

Answer:

(i) 2, 7, 12 ,..., to 10 terms

For this A.P.,

$$a = 2$$

$$d = a_2 - a_1 = 7 - 2 = 5$$

$$n = 10$$

We know that,

$$S_n = \frac{n}{2} [2a + (n-1)d]$$

$$\begin{aligned} S_{10} &= \frac{10}{2} [2(2) + (10-1)5] \\ &= 5 [4 + (9) \times (5)] \\ &= 5 \times 49 = 245 \end{aligned}$$

(ii) -37, -33, -29 ,..., to 12 terms

For this A.P.,

$$a = -37$$

$$d = a_2 - a_1 = (-33) - (-37)$$

$$= -33 + 37 = 4$$

$$n = 12$$

We know that,

$$S_n = \frac{n}{2} [2a + (n-1)d]$$

$$S_{12} = \frac{12}{2} [2(-37) + (12-1)4]$$

$$= 6[-74 + 11 \times 4]$$

$$= 6[-74 + 44]$$

$$= 6(-30) = -180$$

(iii) 0.6, 1.7, 2.8 ,..., to 100 terms

For this A.P.,

$$a = 0.6$$

$$d = a_2 - a_1 = 1.7 - 0.6 = 1.1$$

$$n = 100$$

We know that,

$$S_n = \frac{n}{2} [2a + (n-1)d]$$

$$S_{100} = \frac{100}{2} [2(0.6) + (100-1)1.1]$$

$$= 50 [1.2 + (99) \times (1.1)]$$

$$= 50 [1.2 + 108.9]$$

$$= 50 [110.1]$$

$$= 5505$$

(iv) $\frac{1}{15}, \frac{1}{12}, \frac{1}{10}, \dots$, to 11 terms

For this A.P.,

$$a = \frac{1}{15}$$

$$n = 11$$

$$\begin{aligned}d &= a_2 - a_1 = \frac{1}{12} - \frac{1}{15} \\ &= \frac{5-4}{60} = \frac{1}{60}\end{aligned}$$

We know that,

$$\begin{aligned}S_n &= \frac{n}{2} [2a + (n-1)d] \\ S_{11} &= \frac{11}{2} \left[2 \left(\frac{1}{15} \right) + (11-1) \frac{1}{60} \right] \\ &= \frac{11}{2} \left[\frac{2}{15} + \frac{10}{60} \right] \\ &= \frac{11}{2} \left[\frac{2}{15} + \frac{1}{6} \right] = \frac{11}{2} \left[\frac{4+5}{30} \right] \\ &= \left(\frac{11}{2} \right) \left(\frac{9}{30} \right) = \frac{33}{20}\end{aligned}$$

Question 2:

Find the sums given below

(i) $7 + 10\frac{1}{2} + 14 + \dots + 84$

(ii) $34 + 32 + 30 + \dots + 10$

(iii) $-5 + (-8) + (-11) + \dots + (-230)$

Answer:

(i) $7 + 10\frac{1}{2} + 14 + \dots + 84$

For this A.P.,

$$a = 7$$

$$l = 84$$

$$d = a_2 - a_1 = 10\frac{1}{2} - 7 = \frac{21}{2} - 7 = \frac{7}{2}$$

Let 84 be the n^{th} term of this A.P.

$$l = a + (n - 1)d$$

$$84 = 7 + (n - 1)\frac{7}{2}$$

$$77 = (n - 1)\frac{7}{2}$$

$$22 = n - 1$$

$$n = 23$$

We know that,

$$S_n = \frac{n}{2}(a + l)$$

$$S_n = \frac{23}{2}[7 + 84]$$

$$= \frac{23 \times 91}{2} = \frac{2093}{2}$$

$$= 1046\frac{1}{2}$$

$$(ii) 34 + 32 + 30 + \dots + 10$$

For this A.P.,

$$a = 34$$

$$d = a_2 - a_1 = 32 - 34 = -2$$

$$l = 10$$

Let 10 be the n^{th} term of this A.P.

$$l = a + (n - 1) d$$

$$10 = 34 + (n - 1) (-2)$$

$$-24 = (n - 1) (-2)$$

$$12 = n - 1$$

$$n = 13$$

$$S_n = \frac{n}{2}(a + l)$$

$$= \frac{13}{2}(34 + 10)$$

$$= \frac{13 \times 44}{2} = 13 \times 22$$
$$= 286$$

(iii) $(-5) + (-8) + (-11) + \dots + (-230)$

For this A.P.,

$$a = -5$$

$$l = -230$$

$$d = a_2 - a_1 = (-8) - (-5)$$

$$= -8 + 5 = -3$$

Let -230 be the n^{th} term of this A.P.

$$l = a + (n - 1)d$$

$$-230 = -5 + (n - 1) (-3)$$

$$-225 = (n - 1)(-3)$$

$$(n - 1) = 75$$

$$n = 76$$

$$\text{And, } S_n = \frac{n}{2}(a + l)$$

$$= \frac{76}{2}[(-5) + (-230)]$$

$$= 38(-235)$$

$$= -8930$$

Question 3:

In an AP

- (i) Given $a = 5$, $d = 3$, $a_n = 50$, find n and S_n .
- (ii) Given $a = 7$, $a_{13} = 35$, find d and S_{13} .
- (iii) Given $a_{12} = 37$, $d = 3$, find a and S_{12} .
- (iv) Given $a_3 = 15$, $S_{10} = 125$, find d and a_{10} .
- (v) Given $d = 5$, $S_9 = 75$, find a and a_9 .
- (vi) Given $a = 2$, $d = 8$, $S_n = 90$, find n and a_n .
- (vii) Given $a = 8$, $a_n = 62$, $S_n = 210$, find n and d .
- (viii) Given $a_n = 4$, $d = 2$, $S_n = -14$, find n and a .
- (ix) Given $a = 3$, $n = 8$, $S = 192$, find d .
- (x) Given $l = 28$, $S = 144$ and there are total 9 terms. Find a .

Answer:

(i) Given that, $a = 5$, $d = 3$, $a_n = 50$

$$\text{As } a_n = a + (n - 1)d,$$

$$\therefore 50 = 5 + (n - 1)3$$

$$45 = (n - 1)3$$

$$15 = n - 1$$

$$n = 16$$

$$S_n = \frac{n}{2}[a + a_n]$$

$$\begin{aligned} S_{16} &= \frac{16}{2}[5 + 50] \\ &= 8 \times 55 \\ &= 440 \end{aligned}$$

(ii) Given that, $a = 7$, $a_{13} = 35$

$$\text{As } a_n = a + (n - 1) d,$$

$$\therefore a_{13} = a + (13 - 1) d$$

$$35 = 7 + 12d$$

$$35 - 7 = 12d$$

$$28 = 12d$$

$$d = \frac{7}{3}$$

$$S_n = \frac{n}{2}[a + a_n]$$

$$\begin{aligned} S_{13} &= \frac{n}{2}[a + a_{13}] \\ &= \frac{13}{2}[7 + 35] \\ &= \frac{13 \times 42}{2} = 13 \times 21 \\ &= 273 \end{aligned}$$

(iii) Given that, $a_{12} = 37$, $d = 3$

$$\text{As } a_n = a + (n - 1)d,$$

$$a_{12} = a + (12 - 1)3$$

$$37 = a + 33$$

$$a = 4$$

$$S_n = \frac{n}{2}[a + a_n]$$

$$S_n = \frac{12}{2}[4 + 37]$$

$$S_n = 6(41)$$

$$S_n = 246$$

(iv) Given that, $a_3 = 15$, $S_{10} = 125$

$$\text{As } a_n = a + (n - 1)d,$$

$$a_3 = a + (3 - 1)d$$

$$15 = a + 2d \text{ (i)}$$

$$S_n = \frac{n}{2}[2a + (n-1)d]$$

$$S_{10} = \frac{10}{2}[2a + (10-1)d]$$

$$125 = 5(2a + 9d)$$

$$25 = 2a + 9d \quad \text{(ii)}$$

On multiplying equation (1) by 2, we obtain

$$30 = 2a + 4d \text{ (iii)}$$

On subtracting equation (iii) from (ii), we obtain

$$-5 = 5d$$

$$d = -1$$

From equation (i),

$$15 = a + 2(-1)$$

$$15 = a - 2$$

$$a = 17$$

$$a_{10} = a + (10 - 1)d$$

$$a_{10} = 17 + (9)(-1)$$

$$a_{10} = 17 - 9 = 8$$

(v) Given that, $d = 5$, $S_9 = 75$

$$\text{As } S_n = \frac{n}{2} [2a + (n-1)d],$$

$$S_9 = \frac{9}{2} [2a + (9-1)5]$$

$$75 = \frac{9}{2} (2a + 40)$$

$$25 = 3(a + 20)$$

$$25 = 3a + 60$$

$$3a = 25 - 60$$

$$a = \frac{-35}{3}$$

$$a_n = a + (n - 1)d$$

$$a_9 = a + (9 - 1)(5)$$

$$\begin{aligned}
&= \frac{-35}{3} + 8(5) \\
&= \frac{-35}{3} + 40 \\
&= \frac{-35 + 120}{3} = \frac{85}{3}
\end{aligned}$$

(vi) Given that, $a = 2$, $d = 8$, $S_n = 90$

$$\text{As } S_n = \frac{n}{2} [2a + (n-1)d],$$

$$90 = \frac{n}{2} [4 + (n-1)8]$$

$$90 = n [2 + (n-1)4]$$

$$90 = n [2 + 4n - 4]$$

$$90 = n (4n - 2) = 4n^2 - 2n$$

$$4n^2 - 2n - 90 = 0$$

$$4n^2 - 20n + 18n - 90 = 0$$

$$4n(n-5) + 18(n-5) = 0$$

$$(n-5)(4n+18) = 0$$

Either $n - 5 = 0$ or $4n + 18 = 0$

$$n = 5 \text{ or } n = -\frac{18}{4} = -\frac{9}{2}$$

However, n can neither be negative nor fractional.

Therefore, $n = 5$

$$a_n = a + (n - 1)d$$

$$a_5 = 2 + (5 - 1)8$$

$$= 2 + (4)(8)$$

$$= 2 + 32 = 34$$

(vii) Given that, $a = 8$, $a_n = 62$, $S_n = 210$

$$S_n = \frac{n}{2}[a + a_n]$$

$$210 = \frac{n}{2}[8 + 62]$$

$$210 = \frac{n}{2}(70)$$

$$n = 6$$

$$a_n = a + (n - 1)d$$

$$62 = 8 + (6 - 1)d$$

$$62 - 8 = 5d$$

$$54 = 5d$$

$$d = \frac{54}{5}$$

(viii) Given that, $a_n = 4$, $d = 2$, $S_n = -14$

$$a_n = a + (n - 1)d$$

$$4 = a + (n - 1)2$$

$$4 = a + 2n - 2$$

$$a + 2n = 6$$

$$a = 6 - 2n \text{ (i)}$$

$$S_n = \frac{n}{2}[a + a_n]$$

$$-14 = \frac{n}{2}[a + 4]$$

$$-28 = n(a + 4)$$

$$-28 = n(6 - 2n + 4) \text{ {From equation (i)}}$$

$$-28 = n(-2n + 10)$$

$$-28 = -2n^2 + 10n$$

$$2n^2 - 10n - 28 = 0$$

$$n^2 - 5n - 14 = 0$$

$$n^2 - 7n + 2n - 14 = 0$$

$$n(n - 7) + 2(n - 7) = 0$$

$$(n - 7)(n + 2) = 0$$

$$\text{Either } n - 7 = 0 \text{ or } n + 2 = 0$$

$$n = 7 \text{ or } n = -2$$

However, n can neither be negative nor fractional.

Therefore, $n = 7$

From equation (i), we obtain

$$a = 6 - 2n$$

$$a = 6 - 2(7)$$

$$= 6 - 14$$

$$= -8$$

(ix) Given that, $a = 3$, $n = 8$, $S = 192$

$$S_n = \frac{n}{2} [2a + (n-1)d]$$

$$192 = \frac{8}{2} [2 \times 3 + (8-1)d]$$

$$192 = 4 [6 + 7d]$$

$$48 = 6 + 7d$$

$$42 = 7d$$

$$d = 6$$

(x) Given that, $l = 28$, $S = 144$ and there are total of 9 terms.

$$S_n = \frac{n}{2} (a + l)$$

$$144 = \frac{9}{2} (a + 28)$$

$$(16) \times (2) = a + 28$$

$$32 = a + 28$$

$$a = 4$$

Question 4:

How many terms of the AP. 9, 17, 25 ... must be taken to give a sum of 636?

Answer:

Let there be n terms of this A.P.

For this A.P., $a = 9$

$$d = a_2 - a_1 = 17 - 9 = 8$$

$$S_n = \frac{n}{2} [2a + (n-1)d]$$

$$636 = \frac{n}{2} [2 \times a + (n-1)8]$$

$$636 = \frac{n}{2} [18 + (n-1)8]$$

$$636 = n [9 + 4n - 4]$$

$$636 = n (4n + 5)$$

$$4n^2 + 5n - 636 = 0$$

$$4n^2 + 53n - 48n - 636 = 0$$

$$n(4n + 53) - 12(4n + 53) = 0$$

$$(4n + 53)(n - 12) = 0$$

Either $4n + 53 = 0$ or $n - 12 = 0$

$$n = \frac{-53}{4} \text{ or } n = 12$$

n cannot be $\frac{-53}{4}$. As the number of terms can neither be negative nor fractional, therefore, $n = 12$ only.

Question 5:

The first term of an AP is 5, the last term is 45 and the sum is 400. Find the number of terms and the common difference.

Answer:

Given that,

$$a = 5$$

$$l = 45$$

$$S_n = 400$$

$$S_n = \frac{n}{2}(a+l)$$

$$400 = \frac{n}{2}(5+45)$$

$$400 = \frac{n}{2}(50)$$

$$n = 16$$

$$l = a + (n - 1) d$$

$$45 = 5 + (16 - 1) d$$

$$40 = 15d$$

$$d = \frac{40}{15} = \frac{8}{3}$$

Question 6:

The first and the last term of an AP are 17 and 350 respectively. If the common difference is 9, how many terms are there and what is their sum?

Answer:

Given that,

$$a = 17$$

$$l = 350$$

$$d = 9$$

Let there be n terms in the A.P.

$$l = a + (n - 1)d$$

$$350 = 17 + (n - 1)9$$

$$333 = (n - 1)9$$

$$(n - 1) = 37$$

$$n = 38$$

$$S_n = \frac{n}{2}(a + l)$$

$$\Rightarrow S_n = \frac{38}{2}(17 + 350) = 19(367) = 6973$$

Thus, this A.P. contains 38 terms and the sum of the terms of this A.P. is 6973.

Question 7:

Find the sum of first 22 terms of an AP in which $d = 7$ and 22nd term is 149.

Answer:

$$d = 7$$

$$a_{22} = 149$$

$$S_{22} = ?$$

$$a_n = a + (n - 1)d$$

$$a_{22} = a + (22 - 1)d$$

$$149 = a + 21 \times 7$$

$$149 = a + 147$$

$$a = 2$$

$$\begin{aligned}S_n &= \frac{n}{2}(a + a_n) \\ &= \frac{22}{2}(2 + 149) \\ &= 11(151) = 1661\end{aligned}$$

Question 8:

Find the sum of first 51 terms of an AP whose second and third terms are 14 and 18 respectively.

Answer:

Given that,

$$a_2 = 14$$

$$a_3 = 18$$

$$d = a_3 - a_2 = 18 - 14 = 4$$

$$a_2 = a + d$$

$$14 = a + 4$$

$$a = 10$$

$$\begin{aligned}S_n &= \frac{n}{2}[2a + (n-1)d] \\ S_{51} &= \frac{51}{2}[2 \times 10 + (51-1)4] \\ &= \frac{51}{2}[20 + (50)(4)] \\ &= \frac{51(220)}{2} = 51(110)\end{aligned}$$

$$= 5610$$

Question 9:

If the sum of first 7 terms of an AP is 49 and that of 17 terms is 289, find the sum of first n terms.

Answer:

Given that,

$$S_7 = 49$$

$$S_{17} = 289$$

$$S_n = \frac{n}{2}[2a + (n-1)d]$$

$$S_7 = \frac{7}{2}[2a + (7-1)d]$$

$$49 = \frac{7}{2}(2a + 6d)$$

$$7 = (a + 3d)$$

$$a + 3d = 7 \text{ (i)}$$

Similarly, $S_{17} = \frac{17}{2}[2a + (17-1)d]$

$$289 = \frac{17}{2}[2a + 16d]$$

$$17 = (a + 8d)$$

$$a + 8d = 17 \text{ (ii)}$$

Subtracting equation (i) from equation (ii),

$$5d = 10$$

$$d = 2$$

From equation (i),

$$a + 3(2) = 7$$

$$a + 6 = 7$$

$$a = 1$$

$$\begin{aligned} S_n &= \frac{n}{2} [2a + (n-1)d] \\ &= \frac{n}{2} [2(1) + (n-1)(2)] \\ &= \frac{n}{2} (2 + 2n - 2) \\ &= \frac{n}{2} (2n) \end{aligned}$$

$$= n^2$$

Question 10:

Show that $a_1, a_2, \dots, a_n, \dots$ form an AP where a_n is defined as below

(i) $a_n = 3 + 4n$

(ii) $a_n = 9 - 5n$

Also find the sum of the first 15 terms in each case.

Answer:

(i) $a_n = 3 + 4n$

$$a_1 = 3 + 4(1) = 7$$

$$a_2 = 3 + 4(2) = 3 + 8 = 11$$

$$a_3 = 3 + 4(3) = 3 + 12 = 15$$

$$a_4 = 3 + 4(4) = 3 + 16 = 19$$

It can be observed that

$$a_2 - a_1 = 11 - 7 = 4$$

$$a_3 - a_2 = 15 - 11 = 4$$

$$a_4 - a_3 = 19 - 15 = 4$$

i.e., $a_{k+1} - a_k$ is same every time. Therefore, this is an AP with common difference as 4 and first term as 7.

$$S_n = \frac{n}{2} [2a + (n-1)d]$$

$$S_{15} = \frac{15}{2} [2(7) + (15-1)4]$$

$$= \frac{15}{2} [(14) + 56]$$

$$= \frac{15}{2} (70)$$

$$= 15 \times 35$$

$$= 525$$

$$(ii) a_n = 9 - 5n$$

$$a_1 = 9 - 5 \times 1 = 9 - 5 = 4$$

$$a_2 = 9 - 5 \times 2 = 9 - 10 = -1$$

$$a_3 = 9 - 5 \times 3 = 9 - 15 = -6$$

$$a_4 = 9 - 5 \times 4 = 9 - 20 = -11$$

It can be observed that

$$a_2 - a_1 = -1 - 4 = -5$$

$$a_3 - a_2 = -6 - (-1) = -5$$

$$a_4 - a_3 = -11 - (-6) = -5$$

i.e., $a_{k+1} - a_k$ is same every time. Therefore, this is an A.P. with common difference as -5 and first term as 4 .

$$\begin{aligned} S_n &= \frac{n}{2} [2a + (n-1)d] \\ S_{15} &= \frac{15}{2} [2(4) + (15-1)(-5)] \\ &= \frac{15}{2} [8 + 14(-5)] \\ &= \frac{15}{2} (8 - 70) \\ &= \frac{15}{2} (-62) = 15(-31) \end{aligned}$$

$$= -465$$

Question 11:

If the sum of the first n terms of an AP is $4n - n^2$, what is the first term (that is S_1)? What is the sum of first two terms? What is the second term? Similarly find the 3rd, the 10th and the n^{th} terms.

Answer:

Given that,

$$S_n = 4n - n^2$$

$$\text{First term, } a = S_1 = 4(1) - (1)^2 = 4 - 1 = 3$$

$$\text{Sum of first two terms} = S_2$$

$$= 4(2) - (2)^2 = 8 - 4 = 4$$

$$\text{Second term, } a_2 = S_2 - S_1 = 4 - 3 = 1$$

$$d = a_2 - a = 1 - 3 = -2$$

$$a_n = a + (n - 1)d$$

$$= 3 + (n - 1)(-2)$$

$$= 3 - 2n + 2$$

$$= 5 - 2n$$

$$\text{Therefore, } a_3 = 5 - 2(3) = 5 - 6 = -1$$

$$a_{10} = 5 - 2(10) = 5 - 20 = -15$$

Hence, the sum of first two terms is 4. The second term is 1. 3rd, 10th, and nth terms are -1, -15, and $5 - 2n$ respectively.

Question 12:

Find the sum of first 40 positive integers divisible by 6.

Answer:

The positive integers that are divisible by 6 are

6, 12, 18, 24 ...

It can be observed that these are making an A.P. whose first term is 6 and common difference is 6.

$$a = 6$$

$$d = 6$$

$$S_{40} = ?$$

$$S_n = \frac{n}{2}[2a + (n-1)d]$$

$$S_{40} = \frac{40}{2}[2(6) + (40-1)6]$$

$$= 20[12 + (39)(6)]$$

$$= 20(12 + 234)$$

$$= 20 \times 246$$

$$= 4920$$

Question 13:

Find the sum of first 15 multiples of 8.

Answer:

The multiples of 8 are

8, 16, 24, 32...

These are in an A.P, having first term as 8 and common difference as 8.

Therefore, $a = 8$

$d = 8$

$S_{15} = ?$

$$S_n = \frac{n}{2}[2a + (n-1)d]$$

$$= \frac{15}{2}[2(8) + (15-1)8]$$

$$= \frac{15}{2}[16 + 14(8)]$$

$$= \frac{15}{2}(16 + 112)$$

$$= \frac{15(128)}{2} = 15 \times 64$$

$$= 960$$

Question 14:

Find the sum of the odd numbers between 0 and 50.

Answer:

The odd numbers between 0 and 50 are

1, 3, 5, 7, 9 ... 49

Therefore, it can be observed that these odd numbers are in an A.P.

$$a = 1$$

$$d = 2$$

$$l = 49$$

$$l = a + (n - 1) d$$

$$49 = 1 + (n - 1)2$$

$$48 = 2(n - 1)$$

$$n - 1 = 24$$

$$n = 25$$

$$S_n = \frac{n}{2}(a + l)$$

$$\begin{aligned} S_{25} &= \frac{25}{2}(1 + 49) \\ &= \frac{25(50)}{2} = (25)(25) \end{aligned}$$

$$= 625$$

Question 15:

A contract on construction job specifies a penalty for delay of completion beyond a certain date as follows: Rs. 200 for the first day, Rs. 250 for the second day, Rs. 300 for the third day, etc., the penalty for each succeeding day being Rs. 50 more than for the preceding day. How much money the contractor has to pay as penalty, if he has delayed the work by 30 days.

Answer:

It can be observed that these penalties are in an A.P. having first term as 200 and common difference as 50.

$$a = 200$$

$$d = 50$$

Penalty that has to be paid if he has delayed the work by 30 days = S_{30}

$$= \frac{30}{2} [2(200) + (30 - 1)50]$$

$$= 15 [400 + 1450]$$

$$= 15 (1850)$$

$$= 27750$$

Therefore, the contractor has to pay Rs 27750 as penalty.

Question 16:

A sum of Rs 700 is to be used to give seven cash prizes to students of a school for their overall academic performance. If each prize is Rs 20 less than its preceding prize, find the value of each of the prizes.

Answer:

Let the cost of 1st prize be P.

Cost of 2nd prize = P - 20

And cost of 3rd prize = P - 40

It can be observed that the cost of these prizes are in an A.P. having common difference as -20 and first term as P.

$$a = P$$

$$d = -20$$

Given that, $S_7 = 700$

$$\frac{7}{2}[2a + (7-1)d] = 700$$

$$\frac{[2a + (6)(-20)]}{2} = 100$$

$$a + 3(-20) = 100$$

$$a - 60 = 100$$

$$a = 160$$

Therefore, the value of each of the prizes was Rs 160, Rs 140, Rs 120, Rs 100, Rs 80, Rs 60, and Rs 40.

Question 17:

In a school, students thought of planting trees in and around the school to reduce air pollution. It was decided that the number of trees, that each section of each class will plant, will be the same as the class, in which they are studying, e.g., a section of class I will plant 1 tree, a section of class II will plant 2 trees and so on till class XII. There are three sections of each class. How many trees will be planted by the students?

Answer:

It can be observed that the number of trees planted by the students is in an AP.

1, 2, 3, 4, 5.....12

First term, $a = 1$

Common difference, $d = 2 - 1 = 1$

$$S_n = \frac{n}{2} [2a + (n-1)d]$$

$$S_{12} = \frac{12}{2} [2(1) + (12-1)(1)]$$

$$= 6(2 + 11)$$

$$= 6(13)$$

$$= 78$$

Therefore, number of trees planted by 1 section of the classes = 78

Number of trees planted by 3 sections of the classes = $3 \times 78 = 234$

Therefore, 234 trees will be planted by the students.

Question 18:

A spiral is made up of successive semicircles, with centres alternately at A and B, starting with centre at A of radii 0.5, 1.0 cm, 1.5 cm, 2.0 cm, as shown in figure. What is the total length of such a spiral made up of thirteen consecutive semicircles?

(Take $\pi = \frac{22}{7}$)

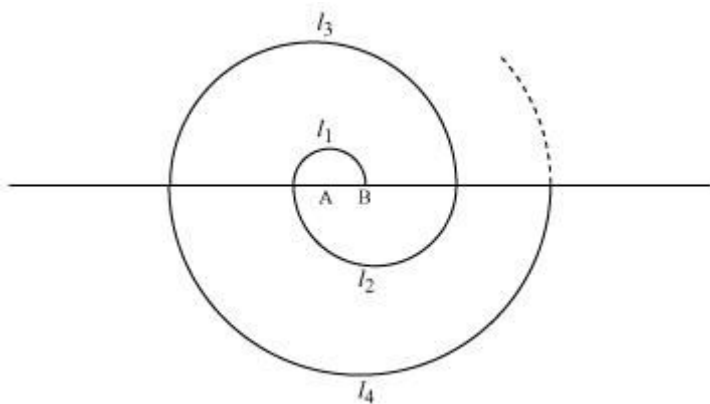

Answer:

Semi-perimeter of circle = πr

$$l_1 = \pi(0.5) = \frac{\pi}{2} \text{ cm}$$

$$l_2 = \pi(1) = \pi \text{ cm}$$

$$l_3 = \pi(1.5) = \frac{3\pi}{2} \text{ cm}$$

Therefore, l_1, l_2, l_3 , i.e. the lengths of the semi-circles are in an A.P.,

$$\frac{\pi}{2}, \pi, \frac{3\pi}{2}, 2\pi, \dots$$

$$a = \frac{\pi}{2}$$

$$d = \pi - \frac{\pi}{2} = \frac{\pi}{2}$$

$$S_{13} = ?$$

We know that the sum of n terms of an A.P. is given by

$$\begin{aligned} S_n &= \frac{n}{2} [2a + (n-1)d] \\ &= \frac{13}{2} \left[2 \left(\frac{\pi}{2} \right) + (13-1) \left(\frac{\pi}{2} \right) \right] \\ &= \frac{13}{2} \left[\pi + \frac{12\pi}{2} \right] \\ &= \left(\frac{13}{2} \right) (7\pi) \\ &= \frac{91\pi}{2} \\ &= \frac{91 \times 22}{2 \times 7} = 13 \times 11 \end{aligned}$$

$$= 143$$

Therefore, the length of such spiral of thirteen consecutive semi-circles will be 143 cm.

Question 19:

200 logs are stacked in the following manner: 20 logs in the bottom row, 19 in the next row, 18 in the row next to it and so on. In how many rows are the 200 logs placed and how many logs are in the top row?

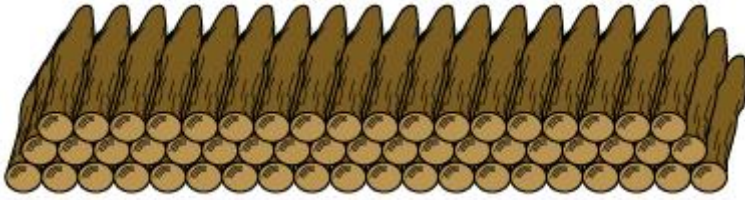

Answer:

It can be observed that the numbers of logs in rows are in an A.P.

20, 19, 18...

For this A.P.,

$$a = 20$$

$$d = a_2 - a_1 = 19 - 20 = -1$$

Let a total of 200 logs be placed in n rows.

$$S_n = 200$$

$$S_n = \frac{n}{2} [2a + (n-1)d]$$

$$200 = \frac{n}{2} [2(20) + (n-1)(-1)]$$

$$400 = n(40 - n + 1)$$

$$400 = n(41 - n)$$

$$400 = 41n - n^2$$

$$n^2 - 41n + 400 = 0$$

$$n^2 - 16n - 25n + 400 = 0$$

$$n(n - 16) - 25(n - 16) = 0$$

$$(n - 16)(n - 25) = 0$$

Either $(n - 16) = 0$ or $n - 25 = 0$

$$n = 16 \text{ or } n = 25$$

$$a_n = a + (n - 1)d$$

$$a_{16} = 20 + (16 - 1)(-1)$$

$$a_{16} = 20 - 15$$

$$a_{16} = 5$$

Similarly,

$$a_{25} = 20 + (25 - 1)(-1)$$

$$a_{25} = 20 - 24$$

$$= -4$$

Clearly, the number of logs in 16th row is 5. However, the number of logs in 25th row is negative, which is not possible.

Therefore, 200 logs can be placed in 16 rows and the number of logs in the 16th row is 5.

Question 20:

In a potato race, a bucket is placed at the starting point, which is 5 m from the first potato and other potatoes are placed 3 m apart in a straight line. There are ten potatoes in the line.

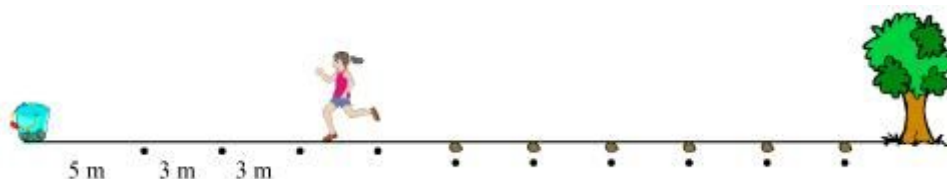

A competitor starts from the bucket, picks up the nearest potato, runs back with it, drops it in the bucket, runs back to pick up the next potato, runs to the bucket to drop it in, and she continues in the same way until all the potatoes are in the bucket. What is the total distance the competitor has to run?

[Hint: to pick up the first potato and the second potato, the total distance (in metres) run by a competitor is $2 \times 5 + 2 \times (5 + 3)$]

Answer:

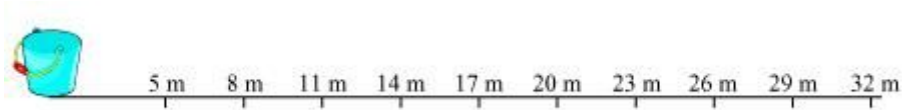

The distances of potatoes are as follows.

5, 8, 11, 14...

It can be observed that these distances are in A.P.

$$a = 5$$

$$d = 8 - 5 = 3$$

$$S_n = \frac{n}{2} [2a + (n-1)d]$$

$$S_{10} = \frac{10}{2} [2(5) + (10-1)3]$$

$$= 5[10 + 9 \times 3]$$

$$= 5(10 + 27) = 5(37)$$

$$= 185$$

As every time she has to run back to the bucket, therefore, the total distance that the competitor has to run will be two times of it.

Therefore, total distance that the competitor will run = 2×185

$$= 370 \text{ m}$$

Alternatively,

The distances of potatoes from the bucket are 5, 8, 11, 14...

Distance run by the competitor for collecting these potatoes are two times of the distance at which the potatoes have been kept. Therefore, distances to be run are

10, 16, 22, 28, 34,.....

$$a = 10$$

$$d = 16 - 10 = 6$$

$$S_{10} = ?$$

$$S_{10} = \frac{10}{2} [2 \times 10 + (10 - 1)6]$$

$$= 5[20 + 54]$$

$$= 5(74)$$

$$= 370$$

Therefore, the competitor will run a total distance of 370 m.

Exercise 5.4

Question 1:

Which term of the A.P. 121, 117, 113 ... is its first negative term?

[Hint: Find n for $a_n < 0$]

Answer:

Given A.P. is 121, 117, 113 ...

$$a = 121$$

$$d = 117 - 121 = -4$$

$$a_n = a + (n - 1) d$$

$$= 121 + (n - 1) (-4)$$

$$= 121 - 4n + 4$$

$$= 125 - 4n$$

We have to find the first negative term of this A.P.

Therefore, $a_n < 0$

$$125 - 4n < 0$$

$$125 < 4n$$

$$n > \frac{125}{4}$$

$$n > 31.25$$

Therefore, 32nd term will be the first negative term of this A.P.

Question 2:

The sum of the third and the seventh terms of an A.P is 6 and their product is 8. Find the sum of first sixteen terms of the A.P.

Answer:

We know that,

$$a_n = a + (n - 1) d$$

$$a_3 = a + (3 - 1) d$$

$$a_3 = a + 2d$$

Similarly, $a_7 = a + 6d$

Given that, $a_3 + a_7 = 6$

$$(a + 2d) + (a + 6d) = 6$$

$$2a + 8d = 6$$

$$a + 4d = 3$$

$$a = 3 - 4d \text{ (i)}$$

Also, it is given that $(a_3) \times (a_7) = 8$

$$(a + 2d) \times (a + 6d) = 8$$

From equation (i),

$$(3 - 4d + 2d) \times (3 - 4d + 6d) = 8$$

$$(3 - 2d) \times (3 + 2d) = 8$$

$$9 - 4d^2 = 8$$

$$4d^2 = 9 - 8 = 1$$

$$d^2 = \frac{1}{4}$$

$$d = \pm \frac{1}{2}$$

$$d = \frac{1}{2} \text{ or } -\frac{1}{2}$$

From equation (i),

$\left(\text{When } d \text{ is } \frac{1}{2}\right)$

$$a = 3 - 4d$$

$$\begin{aligned} a &= 3 - 4\left(\frac{1}{2}\right) \\ &= 3 - 2 = 1 \end{aligned}$$

$\left(\text{When } d \text{ is } -\frac{1}{2}\right)$

$$\begin{aligned} a &= 3 - 4\left(-\frac{1}{2}\right) \\ a &= 3 + 2 = 5 \end{aligned}$$

$$S_n = \frac{n}{2}[2a(n-1)d]$$

$\left(\text{When } a \text{ is } 1 \text{ and } d \text{ is } \frac{1}{2}\right)$

$$\begin{aligned} S_{16} &= \frac{16}{2}\left[2(1) + (16-1)\left(\frac{1}{2}\right)\right] \\ &= 8\left[2 + \frac{15}{2}\right] \\ &= 4(19) = 76 \end{aligned}$$

$\left(\text{When } a \text{ is } 5 \text{ and } d \text{ is } -\frac{1}{2}\right)$

$$\begin{aligned}
 S_{16} &= \frac{16}{2} \left[2(5) + (16-1) \left(-\frac{1}{2} \right) \right] \\
 &= 8 \left[10 + (15) \left(-\frac{1}{2} \right) \right] \\
 &= 8 \left(\frac{5}{2} \right) \\
 &= 20
 \end{aligned}$$

Question 3:

A ladder has rungs 25 cm apart. (See figure). The rungs decrease uniformly in length from 45 cm at the bottom to 25 cm at the top. If the top and bottom rungs are $2\frac{1}{2}$ m apart, what is the length of the wood required for the rungs?

[Hint: number of rungs = $\frac{250}{25}$]

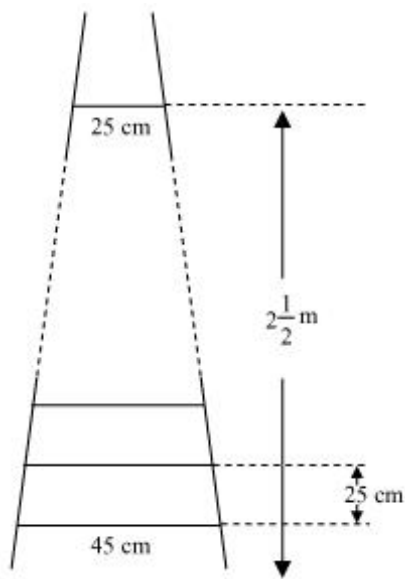

Answer:

It is given that the rungs are 25 cm apart and the top and bottom rungs are $2\frac{1}{2}$ m apart.

$$\therefore \text{Total number of rungs} = \frac{2\frac{1}{2} \times 100}{25} + 1 = \frac{250}{25} + 1 = 11$$

Now, as the lengths of the rungs decrease uniformly, they will be in an A.P.

The length of the wood required for the rungs equals the sum of all the terms of this A.P.

First term, $a = 45$

Last term, $l = 25$

$n = 11$

$$S_n = \frac{n}{2}(a+l)$$

$$\therefore S_{11} = \frac{11}{2}(45+25) = \frac{11}{2}(70) = 385 \text{ cm}$$

Therefore, the length of the wood required for the rungs is 385 cm.

Question 4:

The houses of a row are numbered consecutively from 1 to 49. Show that there is a value of x such that the sum of numbers of the houses preceding the house numbered x is equal to the sum of the number of houses following it.

Find this value of x .

[Hint $S_{x-1} = S_{49} - S_x$]

Answer:

The number of houses was

1, 2, 3 ... 49

It can be observed that the number of houses are in an A.P. having a as 1 and d also as 1.

Let us assume that the number of x^{th} house was like this.

We know that,

$$\text{Sum of } n \text{ terms in an A.P.} = \frac{n}{2}[2a + (n-1)d]$$

Sum of number of houses preceding x^{th} house = S_{x-1}

$$\begin{aligned}
&= \frac{(x-1)}{2} [2a + (x-1-1)d] \\
&= \frac{x-1}{2} [2(1) + (x-2)(1)] \\
&= \frac{x-1}{2} [2 + x - 2] \\
&= \frac{(x)(x-1)}{2}
\end{aligned}$$

Sum of number of houses following x^{th} house = $S_{49} - S_x$

$$\begin{aligned}
&= \frac{49}{2} [2(1) + (49-1)(1)] - \frac{x}{2} [2(1) + (x-1)(1)] \\
&= \frac{49}{2} (2 + 49 - 1) - \frac{x}{2} (2 + x - 1) \\
&= \left(\frac{49}{2}\right)(50) - \frac{x}{2}(x+1) \\
&= 25(49) - \frac{x(x+1)}{2}
\end{aligned}$$

It is given that these sums are equal to each other.

$$\begin{aligned}
\frac{x(x-1)}{2} &= 25(49) - x\left(\frac{x+1}{2}\right) \\
\frac{x^2}{2} - \frac{x}{2} &= 1225 - \frac{x^2}{2} - \frac{x}{2} \\
x^2 &= 1225 \\
x &= \pm 35
\end{aligned}$$

However, the house numbers are positive integers.

The value of x will be 35 only.

Therefore, house number 35 is such that the sum of the numbers of houses preceding the house numbered 35 is equal to the sum of the numbers of the houses following it.

Question 5:

A small terrace at a football ground comprises of 15 steps each of which is 50 m long and built of solid concrete.

Each step has a rise of $\frac{1}{4}$ m and a tread of $\frac{1}{2}$ m (See figure) calculate the total volume of concrete required to build the terrace.

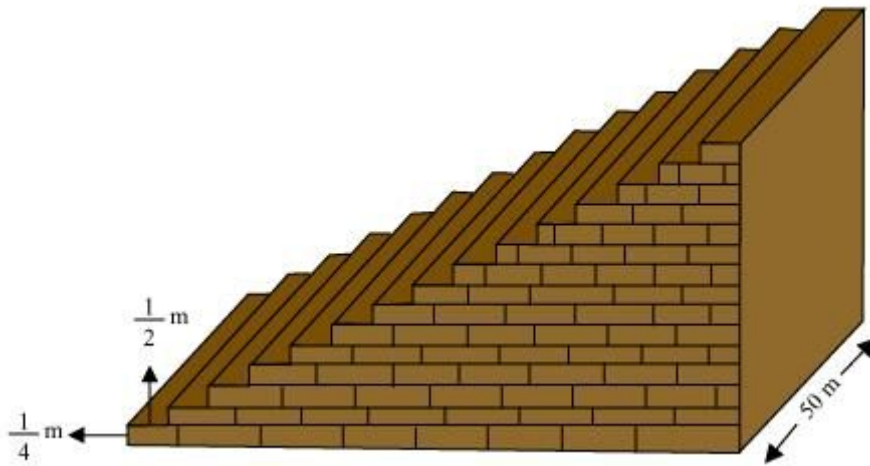

Answer

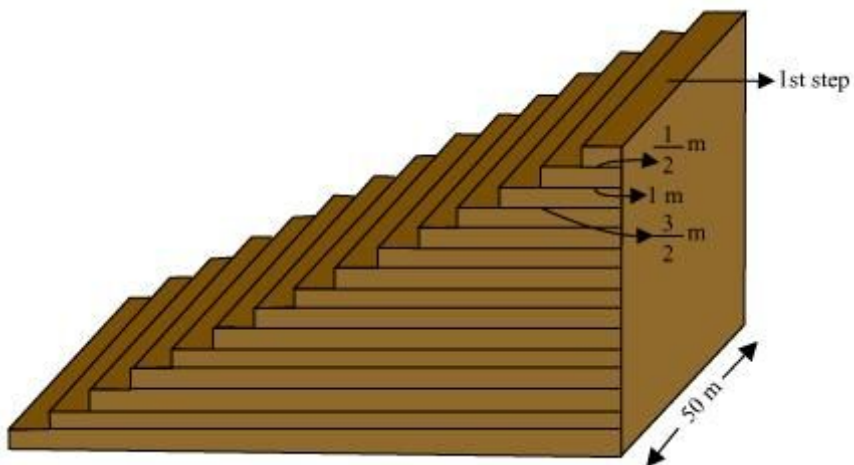

From the figure, it can be observed that

1st step is $\frac{1}{2}$ m wide,

2nd step is 1 m wide,

3rd step is $\frac{3}{2}$ m wide.

Therefore, the width of each step is increasing by $\frac{1}{2}$ m each time whereas their height $\frac{1}{4}$ m and length 50 m remains the same.

Therefore, the widths of these steps are

$$\frac{1}{2}, 1, \frac{3}{2}, 2, \dots$$

$$\text{Volume of concrete in 1}^{\text{st}} \text{ step} = \frac{1}{4} \times \frac{1}{2} \times 50 = \frac{25}{4}$$

$$\text{Volume of concrete in 2}^{\text{nd}} \text{ step} = \frac{1}{4} \times 1 \times 50 = \frac{25}{2}$$

$$\text{Volume of concrete in 3}^{\text{rd}} \text{ step} = \frac{1}{4} \times \frac{3}{2} \times 50 = \frac{75}{4}$$

It can be observed that the volumes of concrete in these steps are in an A.P.

$$\frac{25}{4}, \frac{25}{2}, \frac{75}{4}, \dots$$

$$a = \frac{25}{4}$$

$$d = \frac{25}{2} - \frac{25}{4} = \frac{25}{4}$$

$$\text{and } S_n = \frac{n}{2} [2a + (n-1)d]$$

$$S_{15} = \frac{15}{2} \left[2 \left(\frac{25}{4} \right) + (15-1) \frac{25}{4} \right]$$

$$= \frac{15}{2} \left[\frac{25}{2} + \frac{(14)25}{4} \right]$$

$$= \frac{15}{2} \left[\frac{25}{2} + \frac{175}{2} \right]$$

$$= \frac{15}{2} (100) = 750$$

Volume of concrete required to build the terrace is 750 m^3 .